

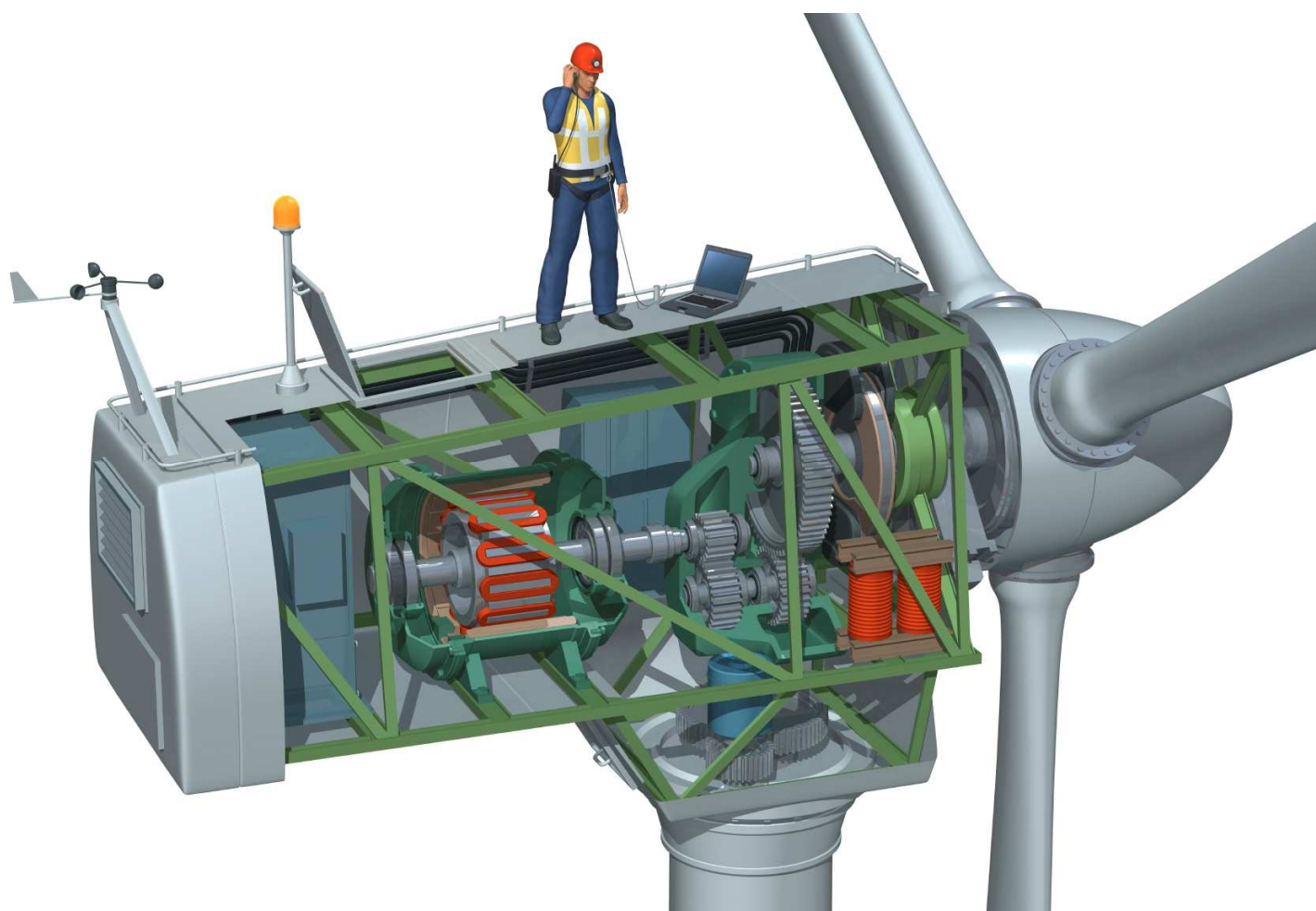

Wind Turbine Generator Safety Compliance in the United States and Canada



Introduction

The U.S. Department of Energy (DOE) is expecting to achieve 20% wind energy or 300 GW of wind generating capacity by 2030¹. Unlike many traditional energy sources, the challenge to achieve this goal is not related to availability of raw materials but rather increasing the manufacturing capacity of wind energy generation equipment. “Achieving 20% wind energy will require the number of turbine installations to increase from approximately 2000 per year in 2006 to almost 7000 per year in 2017.”²

The rapid increase in the annual number of wind turbine installations will draw more manufacturers of Wind Turbines Generators (WTG) and components into the U.S. and Canadian markets. However, before a manufacturer can take advantage of this growing opportunity they need to be familiar with the regulatory requirements pertaining to these markets.

As background, before a WTG can begin operating it must comply with national, state/province and local electrical codes. The person responsible to make this determination is an Authority Having Jurisdiction (AHJ). In the case of WTGs the AHJ is an electrical inspector.

An AHJ can call upon the National or local Codes or Standards as they relate to the WTG as the basis for denying approval to begin operating the unit. If an AHJ challenges a WTG’s compliance to Code the manufacturer is required to make the necessary equipment or installation corrections to satisfy the AHJ’s local code requirements. This must be satisfied before the WTG can begin operating. These corrections often require extensive equipment modifications which can result in costly delays. By understanding of the regulatory issues related to WTGs manufacturers can avoid many potential AHJ objections and unnecessary costly delays.

¹ http://www1.eere.energy.gov/windandhydro/wind_2030.html

² ibid

The purpose of this paper is to provide the manufacturers of WTGs and their components, and WTG customers and investors with information on how to avoid time consuming and costly pitfalls, and improve the overall WTG product safety certification process. This paper contains information on the regulatory issues related to WTGs and provides advance planning tactics to reduce the likelihood of an AHJ objection. What's more, the paper includes best practices to achieve AHJ approval in the event of an AHJ challenge. These methods are based on Intertek's broad experience with power generation equipment and evaluation of over 1,000 WTGs in North America alone.

Key Definitions from NFPA 70, The U.S. National Electric Code, Article 100

Approved. Acceptable to the authority having jurisdiction.

Authority Having Jurisdiction (AHJ). An organization, office, or individual responsible for enforcing the requirements of a code or standard, or for approving equipment, materials, an installation, or a procedure.

Labeled. Equipment or materials to which has been attached a label, symbol, or other identifying mark of an organization that is acceptable to the authority having jurisdiction and concerned with product evaluation, that maintains periodic inspection of production of labeled equipment or materials, and by whose labeling the manufacturer indicates compliance with appropriate standards or performance in a specified manner.

Listed. Equipment, materials, or services included in a list published by an organization that is acceptable to the authority having jurisdiction and concerned with evaluation of products or services, that maintains periodic inspection of production of listed equipment or materials or periodic evaluation of services, and whose listing states that either the equipment, material, or service meets appropriate designated standards or has been tested and found suitable for a specified purpose.

The Regulatory Environment for WTGs

Electrical product safety regulations are based on compliance with the National Electric Code (NEC) in the U.S. and the Canadian Electric Code (CEC) in Canada. The most common means to demonstrate compliance to code is for a manufacturer to have their product "Listed." A Listing is demonstrated by a certification mark such as the ETL, UL or CSA Marks from a third party testing organization such as Intertek, Underwriters Laboratories or CSA, respectively. Such third party testing organizations are called Nationally Recognized Testing Laboratories (NRTL), which are accredited by the U.S. Occupational Safety and Health Administration (OSHA), in the U.S. In Canada, these are called Certification Organizations (CO) and are accredited by the Standards Council of Canada (SCC).

The regulatory issues pertaining to WTG are highly complex for the following reasons:

- There is not an agreed upon standard covering the electrical safety certification of WTGs. Without an agreed upon electrical safety standard it is difficult for third party testing organizations to provide a Listing that is certain to be accepted by the AHJ.
- Since there is not an agreed upon standard covering the electrical safety of WTGs, interpretation regarding specific WTG requirements can vary from state to state and between the U.S. and Canada.
- WTGs are highly complex power generation units containing several thousand components. An AHJ can refuse to commission the entire WTG because of any single component that the AHJ does not consider to be compliant to relevant Code.
- A WTG is not considered a "complete product" until it is assembled at the installation site. Therefore, the Listing must be based on an evaluation of the entire WTG as an assembled entity in the field. The Listing can not be based on factory evaluation as is the case with most electrical equipment.

Because there is no agreed upon standard a WTG can be evaluated to, manufacturers are working with their NRTL / CO to obtain Field Evaluated Labels for their WTGs. A Field Evaluated Label is acquired when an NRTL / CO examines an installed product to ensure that minimum safety requirements have been met. In the U.S. this is typically called a Field Evaluation, and in Canada, a Canadian Special Electrical Inspection (in accordance with standard, CAN/CSA SPE-1000-99). In the case of WTGs the NRTL /CO will consult with the AHJ to identify the certification issues and will propose an evaluation plan to address those issues. When the NRTL /CO is confident the WTG meets with the AHJ's requirements a Field Evaluated Label is provided. Field Evaluations are site-specific, although the data gained on the components may be utilized to qualify future units.

Third Party Certification Requirements

Can manufacturers sell products in the U.S. and Canada without third party certifications?

Compliance to the National Electric Code in the U.S. and the Canadian Electric Code in Canada requires equipment to be Listed by a Nationally Recognized Testing Laboratory (NRTL) in the US, or a Certification Organization (CO) and in Canada. While the CE Marking scheme in Europe can be applied based on self declaration, certification for the U.S. and Canadian markets requires third party certification. Without third party certification an electrical inspector can deny approval for a WTG to begin operation based on National or local Codes or Standards. To date, such challenges have arisen based on lack of compliance with specific sections of the US National Electric Code (NEC – Standard NFPA 70) and the Canadian Electric Code (CAN/CSA C22.2 No. 0). Until the AHJ is satisfied that their regulatory requirements have been met, the installed turbines may not begin operating.

In evaluating the components in a WTG AHJs rely on a third party Listings. When evaluating the entire WTG AHJs work with an NRTL /CO to agree on the requirements for the NRTL /CO to apply a Field Evaluated Label.

Component Listings

How difficult is it to obtain a Listing?

In order to achieve a Field Evaluated Label for a WTG, each component must be examined for compliance with the most applicable National standard. The suppliers of each component will need to have their products tested and Listed. Further, as part of the Listing process each supplier will be subject to continuing factory audits as long as they continue to mark their product under the Listing program.

Due to the increasing global demand for wind energy and the supply chain constraints, many component manufacturers are producing at or near capacity to meet current demand. Since the manufacturers' current certifications enable them to sell in numerous markets, many component manufacturers may be hesitant to go through the Listing process. Furthermore, the timeframe for a Listing evaluation can run from weeks to months. While the certification of cables, control panels, break systems, and wind anemometers can happen quickly, generator and motor manufacturers may not receive results for up to two years on the suitability of their Electrical Insulation System (EIS) to ANSI/UL 1446, a prerequisite to Listing the generator or motor as a whole.

For WTG manufacturers eager to capitalize on the growing U.S. and Canadian markets it is important to plan early. The amount of time it takes to have a product Listed can vary greatly between testing organization. Because of the large number and complexity of the components in a WTG it is important for manufacturers to develop a comprehensive supply chain strategy.

A WTGs and its components are not Listed yet. What needs to be done?

The first step in assessing the scope of your regulatory challenges is to work with an NRTL /CO to conduct a compliance evaluation. The result will be an engineering findings report detailing the items that must be addressed in order to qualify for a Field Evaluation Label.

A desktop examination of your design will identify which components are already Listed. Items that are not Listed are at risk of initiating an AHJ challenge for that component or the electrical system as a whole. With this report in hand, you can identify those items that should be replaced with Listed alternatives and those items that can get Listed by their suppliers. Beginning with items requiring longer lead times for Listing (e.g. Generators) and prioritizing those items typically reviewed by AHJs (e.g. field installed cables, control panels), the NRTL /CO can help you develop a “compliance plan.” For some items, like a light fixture, the easiest solution is to simply replace the item with a Listed equivalent part. However, for an item like the generator, this may be difficult or even impossible based on the availability of currently Listed products.

Next, the NRTL / CO will help ensure that the Listed components are being installed in accordance with the manufacturers’ instructions, and that they’re being used within their ratings.

This early engagement of an NRTL /CO will identify compliance-related risks and help you to avoid costly delays.

What if something needs to be changed in order to qualify for a Field Label?

It is better to identify potential problems early when it is still possible to fix them at the factory rather than when the installation is “complete.” Product retrofits performed in the field become more difficult and more expensive to execute. Many minor modifications can be quickly identified by the inspecting agency engineer and quickly addressed in manufacturing; e.g. adding additional cable supports or warning labels.

What if the AHJ never grants approval, because of some flaw in the design or component selection?

In our experience with more than 1,000 large wind turbines, we have never seen this happen. However, significant field retrofits have been required on some designs at a limited number of sites. So far, to the best of our knowledge, every

unit evaluated under this program has been eventually authorized for labeling and accepted by the AHJ for use.

Why Intertek? Intertek's WTG Resume

Intertek, a NRTL and CO, has developed a unique program that supports manufacturers and AHJs by providing engineering evaluations on installed equipment in order to determine compliance with specific National Codes and Standards, for both the U.S. and Canada. Intertek has Field Evaluated and Labeled over 1,000 large wind turbine generators in the U.S. and Canada. The evaluation techniques employed have been validated by AHJs across North America, resulting in some authorities specifically advising WTG manufacturers to consult with Intertek if they're challenged under the State or Provincial regulations. With our proven experience in efficiently evaluating both the system and component designs to U.S., Canadian, and other International standards, and the desire to support a reasonable and cost-considerate solution acceptable to all involved parties, Intertek stands alone in our ability to guide WTG manufacturers to success for all their U.S. and Canadian projects.

Contact Us

If you'd like to connect with an expert to answer your technical questions, or obtain a quote for a new testing project, contact Intertek at icenter@intertek.com or 1-800-967-5352.

Note: This paper was developed with contributions from Intertek's Energy Services Engineering team and by Joe Welch, Intertek Corporate Liaison, who has been focused on Wind Energy product safety compliance services for the past seven years.